

Product Specifications

Model	LI-14500
Type	Normal Cylindrical Battery
Dimension (Including shrink sleeve/label)	
Diameter (d)	14.1±0.2mm
Height (h)	48.5±0.5mm
Weight	20g (Approx)
Nominal voltage	3.7V
Nominal capacity (0.2C discharge)	850mAh
Minimum capacity (0.2C discharge)	850mAh
Standard charge*	CC: 0.2C (170mA) + CV: 4.2V
Maximum charge voltage	4.2V
Maximum continuous charge current	850mA
Maximum continuous discharge current	1700mA
Discharge cut-off voltage	2.75V
Internal impedance (23±2°C)	75mΩ
Operation temperature	
Discharge	-20-60°C
Charge	0-45°C
Storage temperature (non-condensing)	
Within 1 month	0-45°C
1-3 months	0-35°C
3-12 months	0-25°C

* Note: Standard charge method: 0.2C CC (constant current) charge to 4.2V, then CV (constant voltage) charge till charge current decline to 0.02C (17mA)

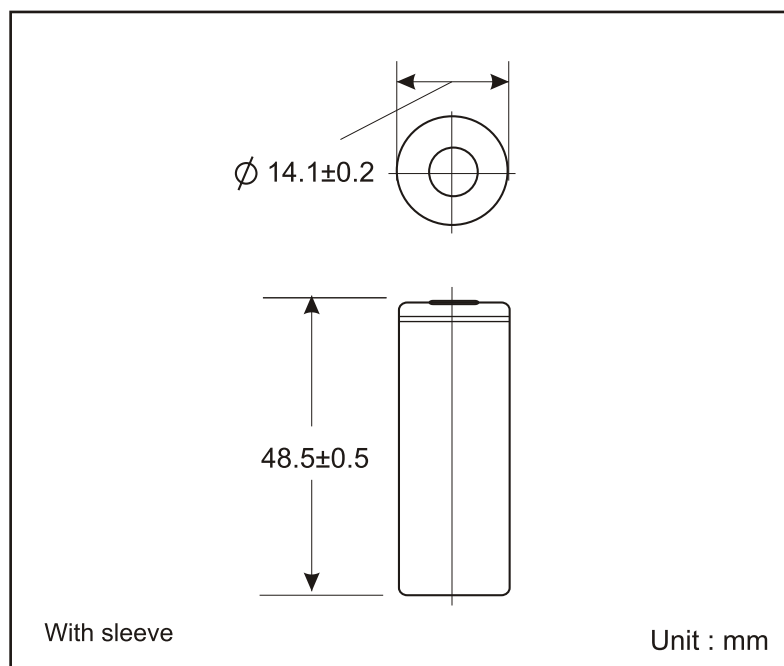

**Note: The data in this document are for descriptive purposes only and subject to change without prior notice.

1. Scope

This specification shall be applied to Lithium ion rechargeable battery cell supplied by Minamoto Battery (HK) Ltd.

2. Testing Environment

Unless otherwise specified, all tests stated in this document shall be performed at $23\pm 2^{\circ}\text{C}$.

3. Performance and Test Conditions

Standard charge: $0.5C=425\text{mA}$ constant current (CC) charge to 4.2V, followed by 4.2V constant voltage (CV) charge until current taper to $\leq 0.01C$.

No.	Test item	Test conditions	Requirements
3.1	Outside Appearance	Visual check	No prominent stain, deformation and damage.
3.2	Outside Dimensions	Vernier clippers	Diameter $14.1\pm 0.2\text{mm}$ Height $48.5\pm 0.5\text{mm}$
3.3	Open circuit voltage	Voltage is tested within 1 week after delivery	3.6V or more
3.4	Internal resistance at delivery	The cell impedance shall be measured by AC method (1kHz) within 1 week after delivery.	75m Ω or less
3.5	Nominal capacity	At standard charging (CH) and discharging at 0.2C	850mAh or more
3.6	Temperature-rate performance	1) Standard CH at R.T Keep batteries in a icebox with ambient temperature of -20°C for 4 hours DCH at 0.2C to the end of DCH voltage at -20°C ; Calculate the capacity ratio with the nominal capacity. 2) Standard CH at R.T Keep batteries in a icebox with ambient temperature of 0°C for 4 hours. Standard DCH to the end of DCH voltage at 0°C ; Calculate the capacity ratio with the nominal capacity. 3) Standard CH at RT Keep batteries in a icebox with ambient temperature of 60°C for 4 hours. Standard DCH to the end of DCH voltage at 60°C ; Calculate the capacity ratio with the nominal capacity..	Capacity ratio $\geq 50\%$ Capacity ratio $\geq 75\%$ Capacity ratio $\geq 95\%$
3.7	Cycle Life	300 cycles of standard CH and standard DCH.	The ratio of discharge capacity at the last and the first cycle $\geq 80\%$

4. Mechanical Performances

No.	Test Item	Test Conditions	Specifications
4.1	Drop	The cell shall be standard charged and then dropped onto hard wood from the height of 75 cm in 3 directions X, Y and Z once at each direction.	No fire or explosion
4.2	Vibration	A standard charged cell shall be vibrated as specified hereunder. Vibration waveform: sinusoidal. Frequency: 16.7Hz. Test time: 1 hour. Vibration direction: arbitrary. Total amplitude: 1mm. After vibration application, the cell shall be standard CH, and then standard DCH.	No explosion and flame, no deformation. Possible to be charged and discharged.

5. Safety Evaluation

No.	Test item	Test Conditions	Specifications
5.1	External short	The cell shall be standard charged. The plus and minus terminals of the cell shall be short circuited with a wire having 50mΩ or less resistance, and left for 1 hour.	No explosion and flame, nor deformation.
5.2	Over charge	After standard charged, the cell shall be charged for 2.5 hours using 10V, 850mA power supply.	No fire, nor explosion.
5.3	Over discharge	The cell shall be standard charged, and discharged with 50Ω resistor load for 24 hours.	No explosion and flame, nor deformation.
5.4	Hot Oven Test	The charged batteries are heated in a gravity convection or circulating air oven. The temperature of the oven is to be raised at a rate of 5±2°C per minute. The oven is to remain for 30 minutes at 130°C before the test is discontinued.	No fire, nor explosion.
5.5	Nail test	A nail with a diameter of 2.5 to 5mm is penetrated vertically through the center of the fully charged battery.	No fire, nor explosion.
5.6	Impact test	A test sample battery is to be placed on a flat surface. A 5/8 inch (15.8mm) diameter bar is to be placed across the center of the sample. A 20 pound (9.1kg) weight is to be dropped from a height of 24+1 inch (610mm) onto the sample.	No fire, nor explosion.
5.7	Crush test	The force for the crushing is to be applied by a hydraulic ram with a 1.25 inch (32mm) diameter piston. The crushing is to be continued until a pressure reading of 17.2MPa is reached on the hydraulic ram, applied force of 13kN.	No fire, nor explosion.

**Note: The data in this document are for descriptive purposes only and subject to change without prior notice.

6. Welding Allowable Part on a Cell
Welding is not allowed on cell side wall.
7. Insulation
Can top face (positive terminal) and side is covered with insulation tubing.
8. Charge State of Battery before Shipment
Approximately 40% charged baseline
9. Storage
Store the battery at low temperature (below 20° C is recommended), low humidity, no dust and no corrosive gas atmosphere.
10. Warranty
Our corporation will repair the cells or batteries for free or replace with new product if there is any fault which is due to material or workmanship during one year from the date of delivery.

Handling Precaution and Prohibitions of Lithium Ion Rechargeable Cells and Batteries

[Danger!]

Electrical misuse

- Use dedicated charger.
- Use or charge the battery only in the dedicated application.
- Don't charge the battery reversely.

Environmental misuse

- Don't leave the battery near the fire or a heated source.
- Don't throw the battery into the fire.
- Don't charge or use the battery in a car or similar place where inside of temperature may be over 60° C .
- Don't immerse, throw, wet the battery in water / seawater.

Others

- Don't store the battery in a pocket or a bag together with metallic objects such as keys, necklaces, hairpins, coins, or screws.
- Don't short circuit (+) and (-) terminals with metallic object intentionally.
- Don't heat partial area of the battery with heated objects such as soldering iron.
- Don't hit with heavy objects such as a hammer, weight.
- Don't step on the battery and throw or drop the battery on the hard floor to avoid mechanical shock.
- Don't disassemble the battery or modify the battery design including electric circuit.
- Don't use seriously scared or deformed battery.
- Don't put the battery into a microwave oven, dryer or high-pressure container.

Don't use or assemble the battery with other makers' batteries, different types and/or models of batteries such as dry batteries, nickel-metal hydride batteries, or nickel-cadmium batteries.

[Warning!]

- Don't use or assemble old and new batteries together.
- Stop charging the battery if charging isn't completed within the specified time.
- Stop using the battery if the battery becomes abnormally hot, discoloration, deformation, or abnormal conditions is detected during use, charge, or storage.
- Keep away from fire immediately when leakage or foul odors are detected.
- If liquid leaks onto your skin or cloths, wash well with fresh water immediately. If liquid leaking from the battery gets into your eyes, don't rub your eyes and wash them with clean water and go to see a doctor immediately.
- If the terminals of the battery become dirty, wipe with a dry cloth before using the battery.
- The battery can be used within the following temperature ranges. Don't exceed these ranges.
- Charge temperature ranges: 0~45°C
- Discharge Temperature ranges: -20~60° C
- Store the battery at temperature below 60° C

[Caution!]

Electrical misuseage

- Battery must be charged with constant current-constant voltage (CC/CV).
- Charge current must be controlled by specified value in Cell specification.
- Discharge current must be controlled by specified value in Cell's specification. Cut-off voltage of discharging must be over 2.75V/cell.
- Keep the battery away from babies and children to avoid any accidents such as swallow. If younger children use the battery, their guardians should explain the proper handling method and precaution before using.
- Before using the battery, be sure to read the user's manual and precaution of it's handling.
- Before using charger, be sure to read the user's manual of the charger.
- Before installing and removing the battery from application, be sure to read user's manual of the application.
- Replace the battery when using time of battery becomes much shorter than usual. Cover terminals with insulating tape before proper disposal.
- If the battery is needed to be stored for a long period, battery should be removed from the application and stored in a place where humidity and temperature are low.
- While the battery is charged, used and stored, keep it away from object materials with static electric chargers.

Design of positioning the battery pack in application and charger

To prevent the deterioration of the battery performance caused by heat, battery shall be positioned away from the area where heat is generated in the application and the charger.